

## ADDITIONAL BRAKE SYSTEM FOR KRAB 84.09

---

System requirements:	Krab 84.09 having flanges (not rollers)
Weight:	6kg approx.
Power:	6V/12V from the Krab accumulator (no additional battery)
Controller:	Switch on the pushing rod (cable connection) / Switch inside the two-ways car (cable connection / wireless)
Function:	Electronic brake eliminates the arresting power of the Krab trolley, reduce the gauge (approx. 4mm) to be able to drive the Krab across the switch points. Main advantage is possibility to operate brakes from the two-ways car cabin.

### Drawings:

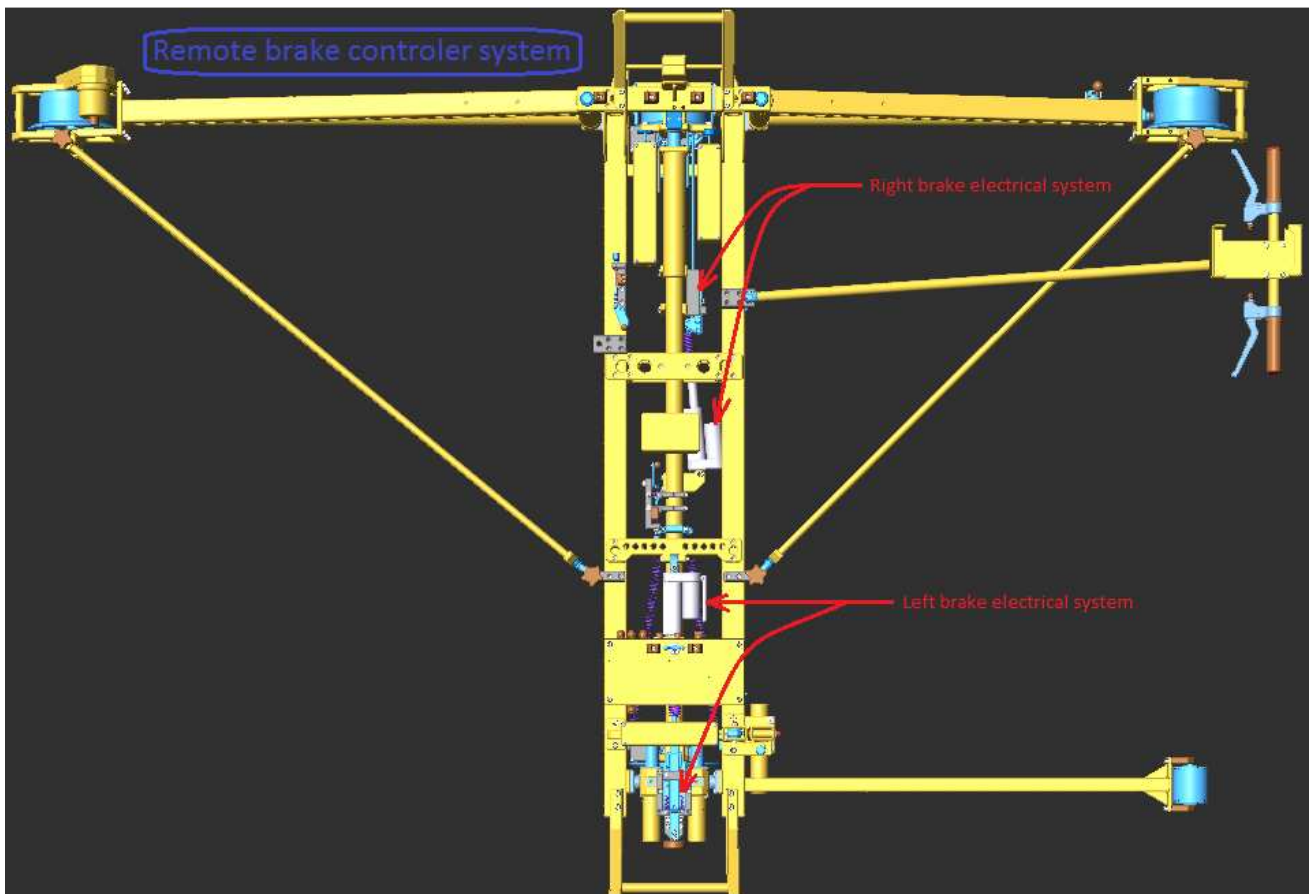

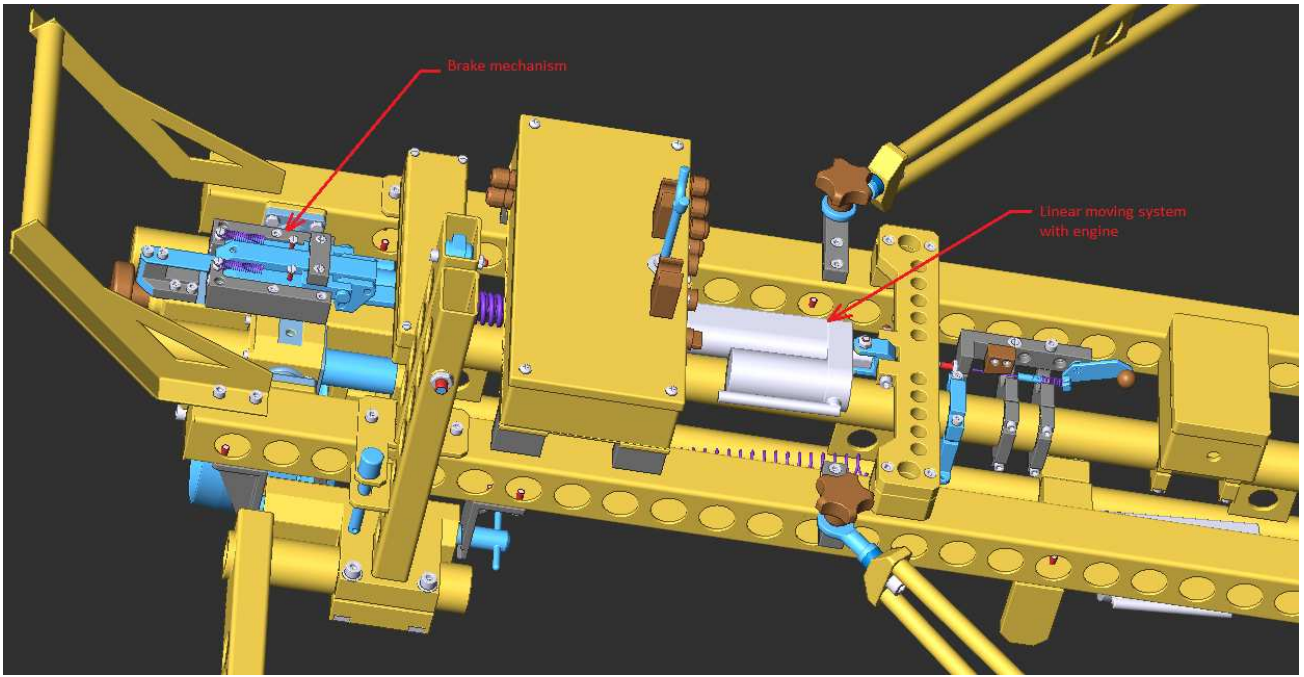

Commercial railway research Ltd.  
U Kaplicky 1199  
165 00 Prague